



From Out of 'The Ashes' Rises

ZXir QLive Alive!

The Timex/Sinclair North American User Groups Newsletter

Jan 7, 94

Volume 3 Number 4

Winter 1993

T/SUNG Chairmen

Here is the list of 1993 T/SNUG Chairmen and how to contact them. We wish to support the following SIGs:- ZX-80/81/TS-1000, Z88, SPECTRUM/TS-2068/TC-2068 and QL. If you have any questions about any of these fine machines, contact the Chairman.

Chairman

Don Lambert (ISTUG)
Chief Motivator
219 925-1372

Vice-Chairmen

D. G. Smith
Tape & JLO Library
814 535-6998

Dave Bennett (CATS)
Z-88
717 774-7531

Ed Snow
QL & ZX-81 Tape
407 380-5124

Rod Gowen (CCATS)
RMG Enterprises
503 655-7484

Rod Humphreys (VSUG)
TS-2068
604 583-2819

Bob Swoger (CATUG)
BBS/LarKen
708 837-7957

Treasurer

Abed Kahale (CATUG)
Cash Tracker/Newsletter
708 885-4337

MEMORY MAP

ROUTINES

ADDRESS

- 1 T/SNUG Chairmen
- 2 T/SNUG Information
- 3 Input/Output - Help - Monitors (Lace!) - Keep'em Coming
- 5 Treasury Note\$ - Membership List
- 13 From The Chairman's Disk

ARTICLES

- 6 Memotech - Memopak Manual
- 8 TS-2068 Talks to a PC by Abed Kahale
- 9 QL Hardware Project - Monitors by Bob Gilder
- 11a Cassette Tape LOAD/SAVE by the late William Pederson
- 12 Tandy CM-11 Monitor
- 14 MSDOS to LKDOS and MSCRIPT by Les Cottrell
- 15 Disk Utility Software (D.U.S.) Review by Don Lambert
- 17 TURBO Switch for the ZX-81/TS-1000 by Tony Willing
- 19 16K MEMOPAK by Don Lambert

SUBROUTINES

- 20 Unclassified Ads
- 22 Public Domain Library List Update
- 27 Toronto's TTSUC QL PD Library
- 28 ZQA! 1991-1993 Index
- 31 Our Dealers
- 32 Dealers' Ads
- 43 Complementary Copies

Established 1991 The Timex/Sinclair North American User Groups Newsletter

Vol. 3 No. 4

ZXir QLive Alive! ©

Winter 93

T/SNUG Information

ZXir QLive Alive! is the newsletter of T/SNUG, the Timex/Sinclair North American User Groups, providing news and software support to the T/S community in at least four newsletters per year; mailed on January, April, August, and October.

It is our goal to build and maintain a Public Domain software library and develop a list of available software for all T/S computers showing the source.

T/SNUG wishes to have one chairman from every T/S user group who will take charge of sending us their group's newsletter contents and other correspondence for inclusion in the ZQA! Newsletter.

We encourage your group to copy this newsletter and distribute it at regular meetings to all your members. If you cannot copy this newsletter, perhaps we can provide a disk with the articles on it.

You can keep T/SNUG alive for an annual contribution of \$10 made payable to Abed Kahale. Send check to:-

ABED KAHALE (LarKen Library)
335 W NEWPORT RD
HOFFMAN ESTATES IL 60195-3106
Phone:- 708 885-4337
Back copies are available for 50¢ each postpaid.

This Newsletter is mailed free to all vendors listed in the "*Our Dealers*" page.

And to the following Users Groups/Newsletters:-

CAPITAL DISTRICT	QZX
CATS	SEATUG
CCATS	SMUG
DTP	TSB
FDD	TTSUC
GCSUG	VISTA
ISTUG	VSUG
LIST	ZX-91
NESQLUG	

ZXir QLive Alive! Articles Contributions

By BBS :- We now have a 24 hour 300-2400 BAUD RBBS. We encourage you to exchange mail and contribute to the download section.

Use extension .ART for articles, .ADS for ads and .NWS for news. Have fun.

Call the BBS at 708 632-5558 and register. On your next call your security level will be increased to 5 for most of the privileges.

For help, contact the SYSOP by leaving a message, mail or phone:-

BOB SWOGER (Chicago Area Timex Users Group)
613 PARKSIDE CIR
STREAMWOOD IL 60107-1647
H 708 837-7957 W 708 576-8068

By tape or disk send your inputs to:-

DONALD LAMBERT
ZXir QLive ALive! Newsletter
1301 KIBLINGER PL
AUBURN IN 46706-3010
Phone 219 925-1372

Or by **hardcopy** mail to:- Abed Kahale (address above)

For software libraries, write or call the following Vice-Chairmen. When writing, please enclose a LSASE .

DAVE BENNETT (Z88)
329 WALTON ST REAR
LEMOYNE PA 17045

ROD GOWEN (CCATS/RMG)
14784 QUAIL GROVE CIR
OREGON CITY OR 97045

ROD HUMPHREYS (VSUG/2068)
10984 COLLINS PL
DELTA B C V4C 7E6 CANADA

D G SMITH (2068 TAPE Library & JLO)
R 415 STONE ST
JOHNSTOWN PA 15906

ED SNOW (ZX-81 TAPE & QL)
2136 CHURCHILL DOWNS CIR
ORLANDO FL 32825

Input/Output

by *Abed Kahale*

Help!

"I am a retired TS2068 user who continues to use the 2068 computer.

About 10 years ago I put together a program that produces fishing and hunting times as a hobby. I had a 2068 user out east (Imre Augsberger) write the technical code to calculate the various times, i.e., sunrise, sunset, etc. Imre, who is an astronomer, can't be located. Unfortunately, he made use of Function Calls in his calculations." .. "My problem is that the 2068 takes about 4 hours to perform the calculations necessary for me to produce one set of 52 weeks of tables for one customer. Now this is O.K. when I go fishing ... I just load it up and start it running." .. "Is there anyone who could help? I would be willing to pay, of course."

Jack H. Payne

Solunar Services, Inc.

1107 N. Morgan St.

Rushville IN 46173



Dick Wagner, CCATS and Secretary of the PLOTTER came to the rescue.

William B. Horner III called (Don Lambert) with a question about how to connect up a Radio Shack High Resolution Color Monitor (CM-11) to his Sinclair QL with TK2, Cumana and dual disk drives. He sent me a spec. sheet on the CM-11 and it is elsewhere in this newsletter. Can anybody out there help him out? He has connected it up one way (not detailed) and the screen rolls, another way and the screen leans drastically to the left. Don. 0/0

WILLIAM B. HORNER III

4311 BUCKINGHAM

DETROIT MI 48224

I hate to be the one to bring you bad tidings. A non-interlaced monitor is not compatible with Sinclair Computers. However, all is not lost; see the HARDWARE PROJECT by Bob Gilder of LIST elsewhere in this issue.

LACE!

Televisions (NTSC) and interlaced monitors sequentially scan 262.5 odd then even lines per each frame (frame = 1/30 of a second) while non-interlaced monitors scan the whole 512 lines per frame to deliver flicker free picture. The fairly new "high resolution non-interlaced monitors" deliver state-of-the-art picture quality, unfortunately we can not benefit from them.

The 2068 can deliver a composite color picture to the VIDEO input on a TV or through the VCR video input to a TV. The QL (per Nazir Pashtoon) is capable of delivering excellent black and white picture to the same. Of course RGB monitors are best suited to our computers if they can be found.

Keep'em Coming

David E. Lassov System Oriented Languages Corp. of Tucson AZ:- "Thank you for continuing your fine support of Timex/Sinclair products. While my first such machine was a TS1000, the extra color, memory, and expandability of the 2068 have dominated my interests in personal computing to such an extent that the (open) 2068 system is my main, and the (closed) Apple II C+ is relegated to support duties." .. "We need more interesting articles; and I for one, intend to submit more such material. It has been a long time coming for me, but we now have a handle on Bill Jones' fine word processor and disk data base manager and we mean to use it." .. "Wow !!!!!!! Where did you get all those disks? I want them all, and now, not later."

We thank you for your support. The Public Domain Library disks were received by him.

Francine Sklar of Loch Sheldrake NY:- "I let my membership lapse, could I get the back issues of 1993?" .. " I have changed my address." "Although I still use the TS2068, the Z88 is the machine I use most frequently. I would be most interested to read articles on ZBASE.

How about it Z88 users?

Greg Simmons of Peoria IL:- "I would like to join the T/SNUG. I am interested in the TS2068 computer." " I have always been a fan of the Sinclair line of computers." .. " I lost track of the Sinclair users for a while. I found them again when I saw an ad in the Computer Shopper for UPDATE! Magazine. I found a wealth of information on the Sinclair computers and people that still sell and support the computers." " I hope to restock on the Sinclair line of computers soon. I have read a little of a disk drive for the 2068 called LarKen Disk Interface. Can you help and explain about the Disk Interface and

where can I obtain a LarKen?

A response was mailed including suggestion to check with RMG, Ed Grey and John Olinger.

Quentin Kent of Allentown PA:- Called to find out whether Timex/Sinclair is still alive! He requested information about upgrading his 2068 to disk drive and all of the ZQA! available issues.

Where can I obtain a disk interface?

A response was mailed: The LarKen Disk Operating System is the most popular that provides interface to 4 disk drives, SS-DD(200K), DSDD(400K), and QUAD(800K), a RAMDISK too (256K). Larry Kenny is no longer supplying the boards but there maybe

some around like at RMG Enterprises, Mechanical Affinity and Ed Grey. The John Olinger Co. interface is still available (see ad in this issue, retyped from the Toronto Sinc-Link). The two interfaces are not compatible. Also check AERCO.

"Dealers - Do you have Larken?
Please drop me a line and let us all know. Ads are for free."

Our thanks go to Bill Russell for providing quit a few Timex/Sinclair users with reference to ZXir 2Live. Alive!

Gilliam Parrish of Beggs OK:- "Dear Don," "Got the last issue of ZQA! — still doing a great job. And I again got the guilty feeling I wasn't doing anything to help the cause." "A while back, I got directly from Byte-Back a 300 BAUD modem/serial interface. The device comes with terminal software and RS-232 printer driver software. The modem certainly works; I used it to contact a local BBS which allow users to set the number of columns they wish to receive (quit a benefit when you have only a 32-columns screen!). First (and to be fair, this is clearly stated in the ad), the device does not support x-modem or similar program transfers, although it will support limited transfers between two ZX/TS machines. I am not clear if this is a limitation of the modem, the supplied terminal software, and/or a relatively easy hardware hack, that would allow x-modem transfers on these modems? Secondly, although some sources indicate the serial interface on the device can be used to connect to a faster modem, nothing in the supplied RS-232 software appears to be relevant to anything but a serial printer. Does anyone have other terminal software designed for such an RS-232 interface and a faster (say 2400 BAUD) modem?"

Another question, you mentioned in the Newsletter getting a 16K Memopak expander

with DIP switches. Can you tell me the DIP switch settings, to use it with another 16K expander for 32K total?.. "A few weeks ago in a thrift store, I ran into a fully functional 2068 and 2040 going for about \$8 total. I'd like to stumble onto a few more of those deals!"

"Do you know of any source for those 4" wide aluminum coated rolls of electrostatic paper, used by the ZX Printer?"

See the MEMOTECH instructions next page. Bob Swoger, who owns a MEMOTECH modem, is trying to find answers to your questions.

The only software available for the 2068 that provides more than the 300 BAUD is LarkEn MaxCom that requires a serial port to go on-line at 1200.

For the ZX-Printer, try the thermal paper which is still available from our dealers, I believe. Otherwise, Radio Shack carries slightly narrower paper rolls.

Errata

Page 17 of the Fall 93 issue, Line 7 of the program should read:-

7 RANDOMIZE USR 100: POKE
8214, 16100

Trea\$ury Note\$ Supporting T/SNUG

		Date
Paul	Anderson	5/93
Ronald	Baty	6/93
Dave	Bennett	8/93
Don	Berry	11/92
Alvin	Bluman	6/93
Daniel	Chattin	7/93
Les	Cottrell	6/93
Jamie	Cruz-Figueroa	11/93
Robert ☺	Curnutt	8/93
Frank	Davis ISTUG	9/92
Daniel	Elliott Computer Classics	5/93
Ruth	Fegley	5/93
Ferdinand	Gunther	5/93

Robert	Hartung	4/93
Fred	Henn	7/93
Fredrick	Hill	4/93
William ☺	Horner	12/93
Glenn	Hufstedler	7/93
Rod	Humphreys VSUG	Charter
Warren	Jackson	4/93
Edward	Jordan	6/93
Jon	Kaczor GCTSUG	8/93
Joan	Kealy	4/93
Quentin ☺	Kent	12/93
Wayne	Knaust	2/93
Jeffrey	Kuhlmann	7/93
Donald	Lambert T/SNUG ZQA!	4/93
David	Lassov	12/93
David	Leech Byte-Back	9/92
Robert	Madaris	5/93
Lt. Col. Walter	Malin	3/93
Lafe ☺	McCorkle	9/93
Harry	Miller Jr	5/93
Frank	Mills CATUG	5/93
Gregory	Newkirk	5/93
Gilliam	Parrish	12/93
Jack ☺	Payne	10/93
Hugh	Polley	5/93
Hugh	Scriven	11/92
Greg ☺	Simmons	11/93
Louis	Simon	6/93
Francine	Sklar	12/93
Edward	Snow	5/93
Dane	Stegman	8/93
Mike	Stephens	7/93
Alexander	Sweitzer	7/93
Ivan	Zachev	12/93
Wesley	Zapotochna	6/93

FLA

☺ Welcome,
New Members

As of December 31, 1993

we have a balance of \$388.56

Abed Kahale Treasurer

The Timex/Sinclair

North American User Groups

MEMOTECH

MEMOPAK 64K

A few of our readers requested this information.

There are two memory locations which you change in order to tell the computer the upper limit of your memory (or RAMTOP). These are 16389 and 16388.

To set top of RAM at 64K, type the following:

POKE 16388,255 (this is not usually needed)

POKE 16389,255 (this is usually set at 128 for a 32K limit)

NEW (the memory is now cleared to start afresh; and will now be organized to the new limit).

To check the current top of RAM, type **PRINT PEEK 16389** and the value 255 should appear in the top left-hand corner of the screen. For a quick check that the memory is now at your finger-tips you can now try the following little programs:

```
10 DIM A$(90,500)
   or
10 DIM A(9000)
   or
10 POKE 65000,128
20 PRINT PEEK 65000
```

These programs reach the top end of memory. Remember numeric fields take up five bytes. (Tip: if you want to store more numbers and they are integers which don't exceed 255, then why not use the CODE and CHR\$ functions to store values as single byte characters?).

How can I test that all my variable locations are good?

First, set the top of RAM back to 32K (either POKE 16389, 128 or just power up again).

Type in this program which will test every bit in the 32-64K area, in FAST mode.

```
10 FAST
20 FOR I = 32768 TO 65535
30 POKE I,255
40 LET A = PEEK I
50 POKE I,0
60 LET B = PEEK I
70 IF A<>255 OR B<>0 THEN
   GOSUB 130
100 NEXT I
110 PRINT "END OF RAM TEST"
120 STOP
130 SLOW
140 PRINT "ERROR AT: ";I
150 STOP
160 FAST
170 RETURN
```

You can find how far your program has got by doing a BREAK. Resume by using CONT. The program will print an error message if a bad location is found, and halt. By keying CONT, the program will continue its testing. If it reaches "END OF RAM TEST" without having shown an error, you're now ready to start that BIG program.

What is where?

First of all, our pack does contain a full 64K RAM (and this can be used by other Z80 processors, in principle). But the ZX81 can only address 64K locations altogether, and the first 8K are obviously dedicated to its own ROM. So although we've got 64K RAM, and the ZX81 can address 64K locations, this MEMOPAK cannot add on more than 56K to the ZX81 ROM. This brings the ZX81 - MEMO-PAK configuration to 64K total. The original 1 K of RAM of the ZX81 (located at 16K +) is disabled and its functions will take place in the MEMOPAK 64K RAM. Confused? There is a diagram on the inside cover to sort it out. The main thing to remember is that the top 48K is automatically used by the ZX81 BASIC.

As programs are entered into the system the elements are sifted into the instruction file and the array file. The instruction file, the display file (holding screen data) and the array file lie next to each other in that order at the bottom end of memory. Gradually, as the instruction file increases, the other files are pushed up through memory. Remember, the original 1 K of RAM in the ZX81 (located at 16K+) has been disabled and all its functions take place in the MEMOPAK.

This pushing goes on until either the array file reaches the top of the memory or until the display file begins to straddle the 32K mark (by going above 32767).

Does this mean if I've got 32K or more of RAM, I still can't have more than 15K or so of instructions?

No. Many people think you are restricted but there is a neat trick where you can force your display file to leap the 32K mark in one bound by putting in a large, dummy instruction. The important thing is to make sure that the display file never straddles the 32K mark. Here is how:

a) On input, check from time to time the value in the VARS system variable, as this lies just above the end of the display file:

```
PRINT PEEK 16401 * 256 + PEEK 16400
```

b) When the values of VARS approaches 32767, enter a huge line into the program, like: LET ZERO = ○ + ○ + ○ + ○ etc. with about 100 repetitions of [+0]. This will push the display file entirely above 32768.

c) Check the system variable D-FILE to make sure the display file now begins above 32768:

```
PRINT PEEK 16397 * 256 + PEEK 16396
```

If it is, then you can carry on programming.

What about the mysterious 8-16K area?

On the ZX81 this area does not exist. We have supplied it, and you can now reach it directly in your BASIC program, using PEEK and POKE, or with machine code. The sort of

thing you can use it for will depend on how expert you are, but we can suggest:

- a) Storing data and machine code sub-routines
- b) Passing them from one program to another
- c) Memory-mapping buffer areas for add-ons.

For Sinclair ZX80/81 users, the simplest thing is to set switches 2 and 3 ON and 1 and 4 OFF (MODE E). This gives the biggest possible area. This is how the pack leaves us, and normally there will be no need to change the settings. The other settings are intended to accommodate the needs of special add-ons being developed.

MODE	SWITCH			
	1	2	3	4
A	ON	OFF	OFF	OFF
B*	OFF	ON	OFF	OFF
C*	OFF	OFF	ON	OFF
D*	OFF	OFF	OFF	ON
E*	OFF	ON	ON	OFF

This mode is not compatible with the ZX80/81 but offers a full 64K RAM to a Z80 that is designed to address it.

Memory is available in the 12-16K area.

Memory is available in the 8-16K area.

No memory is available in the 8-16K area.

Memory is available in the 8-16K area.

* In these cases, 48K for normal BASIC work is still available. Memory made available in the 8-16K area can be used with PEEK and POKE, or for machine code. For ZX81 users, switching between modes B, C, D and E is possible, as long as at least one and no more than two switches are ON at the same time. Never have more than two switches ON at a time, as this can lead to overloading. Remember ON is UP!

Have you any tips for running a full ZX81 system?

Yes. These may or may not help in your situation. When connected to MEMOPAK 64K and printer, make sure that LOADING takes place with cassette recorder volume set at maximum. If possible, make sure that your cassette recorder and ZX81 are plugged into different main sockets. With some cassette recorders, you shouldn't have the LOAD (EAR) and SAVE (MIKE) connectors plugged in at the same time. LOADING is more likely to be successful if you quote the file name, rather than null (" "). Clean your connectors regularly. Don't use the first twenty seconds of a cassette tape, as that is where a lot of LOAD bugs live.

Can I run programs written for a 16K pack on the Memopak 64K?

Yes, they should run straight away, but things are a little tricky if you want to enlarge your arrays to use the larger memory and you have been SAVEing your data. Basically,

you have to re-enter all data after you have re-dimensioned, to be sure that the right data is going to be accessed. What we suggest is:

- a) LOAD the original program.
- b) Edit in a special routine which will list and label the contents of all variables on the printer.
- c) Run this routine. You now have a hard copy of your data.
- d) Re-set your dimensions. Also enter a routine to allow you to re-input all your old values plus any new ones.
- e) Run your program and enter the values.

One more thing, to use the memory fully it is much better to use a multi-dimensional string array rather than a simple string, since the ZX81 limits single string sizes to a maximum length of 16K, and also duplicates it unnecessarily.

A couple of program examples

BASIC strings are stored in the instruction area of RAM (16-32K). This means that when you set a literal, say, LET A\$ = "CAT" the word CAT is actually duplicated, once as a literal as part of the instruction, and once in the variable area A\$. It would be more economical if we could set up an initialization routine which would store all literals once only in the variables area. This simple loop would let you input up to 10 strings of 20 characters each:

```
10 DIM A$(10,20)
20 INPUT I
30 IF I = 0 THEN GOTO 70
40 INPUT B$
50 LET A$(I) = B$
60 GO TO 20
70 INPUT I
80 IF I = 0 THEN GOTO 110
90 PRINT A$(I)
100 GOTO 70
110 REM AUTOMATIC SELF SAVE
120 SAVE "SELF"
130 GOTO 20
140 STOP
```

Breakdown:

Lines 20-60 Store strings

Lines 70-100 Display strings

Lines 110-140 Save program with string arrays

Now look carefully at the instructions from line 110. With increased array capacity in the memory you will probably want to store your data more permanently. The ZX81 system does not (at least as yet) support free-standing files but it is possible to save your arrays (and their contents) along with your program. However, it is important that when you next load the program, it does not carry out a RUN but a GOTO instead; otherwise RUN will automatically clear the arrays. This program will SAVE itself automatically (line 120). When you next LOAD it will pick up straight away at line 130 the line after the SAVE and branch back to the line quoted there (in this case 20). In this way, the RUN instruction is avoided and the variables are not cleared. But make sure you don't branch back to a point where you re-dimension the array you're trying to save!

Good luck from all at MEMOTECH!

TS-2068 Talks to a PC by Modem

by *Abed Kahale*

It has been a challenge to have a 2068 communicate directly via modem with a PC modem to transfer text files. The procedure was to upload files to a BBS by one computer and then download with the other, until Bob Swoger spent an evening with me to tackle this problem.

To communicate, modems have to have a line that has a tone "carrier" and provides a ring "signal". Connecting two modems together from two computers eliminates the carrier and the signal and the modems will not turn on. It has been done with the two modems connected to the same phone line that held up calling or receiving phone calls for the duration, at 18 text characters per second which is what I got with the 2050 modem.

With a Hayes compatible PC modem, here is how:-

1. Connect the two modem lines that normally go to the telephone line together using a two-line plug without any connections to the telephone line.
2. Turn on both modems and load the modems software. MTERM II (Loader V) or MaxCom Xmodem for the 2068. Load buffer etc. I used MaxCom.
3. Set both computers to terminal mode and the TS-2068 to ASCII (toggle con: none). All other parameters have to match the PC modem's of course or vice versa.

The following has to be done rapidly before the PC abandons the connections.

4. On the PC modem, ENTER ATA (which is Hayes command that forces the PC modem to answer the phone without the

benefit of a ring or a tone). The PC modem emanates a long squeal and recognizes the signal from the other modem and connects.

5. Set the PC in RECEIVE mode, Xmodem 300 BAUD and enter the file name.
6. From the TS-2068 select SEND (transmit) file "name.Cm" and ENTER.
7. The PC acknowledges and receives the file.
8. Exit SEND to TERMINAL mode and ENTER Ctl Z (SHIFT-7 Z) to tell the PC "end-of-file".

I asked Don to send his input in MSCRIPT on disk, it worked as you can see the results in the "From the Chairman's DISK". Don, please! No (%%%) line, the PC goes crazy with these placeholders.

I mailed a brief version of the above to Electronics Now

Magazine after reading K. G. Pratt letter.

Electronics Now January 1994 LETTERS Page 17

"..... I wanted to transfer several megabytes from the files of my 1983 model Timex/Sinclair TS2068 computer to an IBM-compatible 286 PC with modem. The TS2068 has 64K of memory, etc The TS2068 uses a non-ASCII code and cannot be directly connected to a PC.

However, the hardware and software associated with the modem allow the transmission of ASCII files. Therefore, the two computers can be connected by phone line. ... It ties up the person's phone line .. I had transferred some sensitive material by printing them out from the 2068 and later reading them by an optical character reader (OCR scanner) into the PC."

K. G. Pratt
Newport News, VA

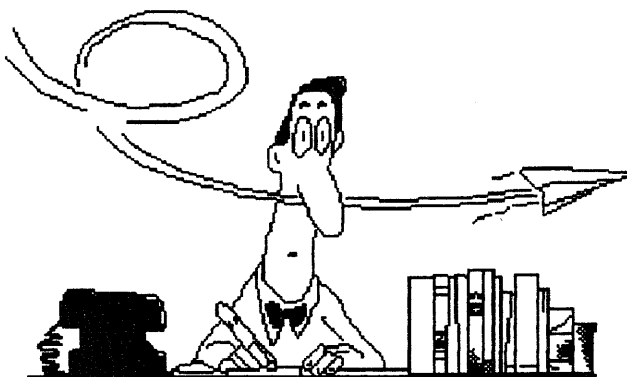

QL To IBM RGB Monitor Connections

In the past few weeks I have had three requests for information on how to hook-up an IBM CGA or RGB Monitor to a QL. The following information will allow anyone with soldering experience to make an appropriate cable between the QL and an RGB monitor.

The only problem you may encounter is with the horizontal sync inversion from a negative going sync signal from the QL to a positive going horizontal signal required for most, if not all, American CGA/RGB monitors.

In the following diagrams, I use a 74LS00 TTL IC (Quad 2-input positive-nand gate), of which we will use pins 1 and 2, tied together to form an inverter input. The signal from the QL, which is negative, enters the input of the inverter, pins 1 & 2. The sync signal is now inverted within the IC and a positive horizontal sync signal is available at pin 3 which is connected to the horizontal pin on the monitor connector.

If you happen to have a 74LS04 Hex inverter IC, it also can be used - just use pin 1 as the horizontal input from the QL and pin 2 will be the inverted sync signal output connected to the monitor connector.

All parts for this project can be purchased at any Radio Shack store. In addition to purchasing the two connectors and IC, you will need a 9 pin 'D' connector hood, which if you are careful, can house the IC - just carefully clip all unused pins on the IC and bend pins 1, 2, 3, 7, & 14 in towards the center of the IC. Solder the wires with minimum solder and install the IC upside down (pins facing up) and the two piece connector hood will house it, allowing a clean appearing installation. You will also need a length of cable determined by your requirement. The cable need only be 7 conductors, or if you wish, use 7 - single lengths of multi-stranded wire to form your cable.

Male 9 Pin 'D' plug (solder pin side)

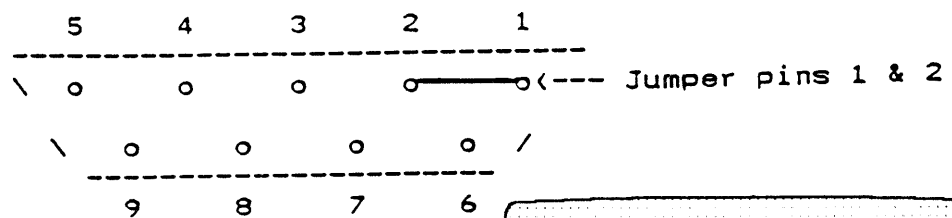

Connections to the male 9 pin 'D' connector

Pin #'s

- 1 Ground (common)
- 2 Ground (common)
- 3 Red (RGB signal)
- 4 Green (RGB signal)
- 5 Blue (RGB signal)
- 6 N/C (no connection)
- 7 N/C (no connection)
- 8 Horizontal Sync (negative signal - must be inverted)
- 9 Vertical Sync (Most monitors do not require Neg. sync)

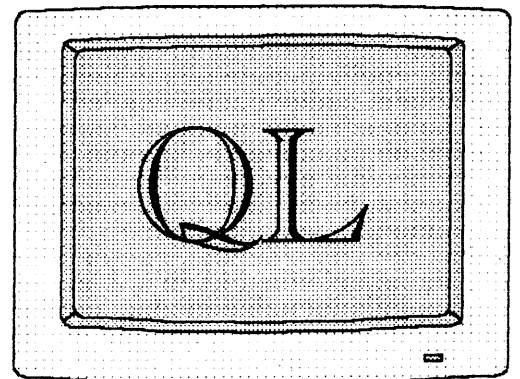

ground ->7	o 7 o	8	IC-1 will only have
Use pin #7, IC-1 as common			5 pins used, #'s 1, 2,
Ground points for both	6 o 4 o	9	3, 7, and 14.
cable connectors -			
(9 pin 'D' pin # 1 & 2)	5 o L o	10	
(8 pin 'Din pin # 2).	4 o S o	11	
Horiz Sync out to 9 pin<-3	o 0 o	12	
'D' connector, pin #8.			
Horiz Sync input from ->2	o 0 o	13	
QL connector (pin #4)	o		
(Pins 1 & 2 are jumped	1 o o	14<-	+5 volts from QL connector
together to form an			(Pin #1).
inverted signal input).			

74LS00 TTL IC wired as an inverter - IC-1
Bottom side up (pins up)

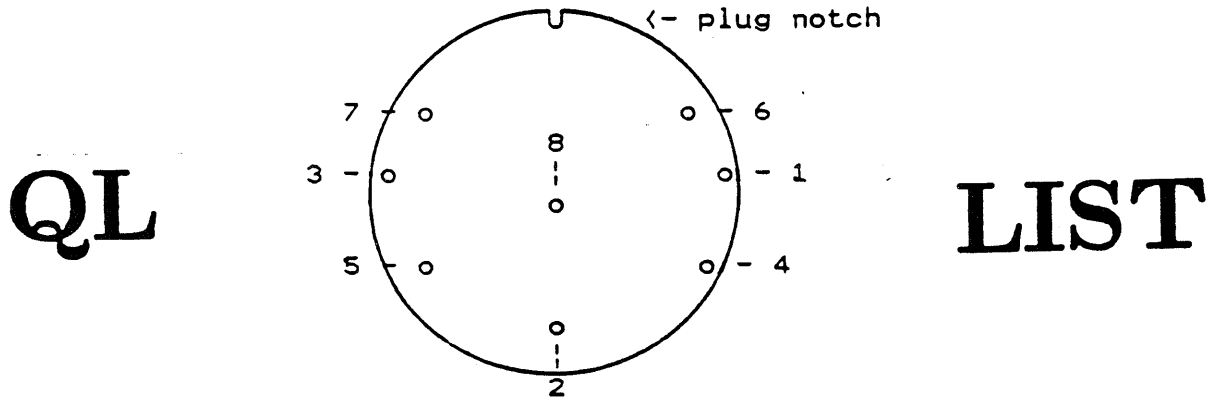

8 Pin DIN connector(solder pin side)

Connections to the male Din 8 pin connector

Pin #'s

- 1 + 5 volts DC
- 2 Ground (common)
- 3 Composite Signal (not used for RGB)
- 4 Horizontal Sync (negative sync - must be inverted)
- 5 Vertical Sync (Most monitors do not require Neg. sync)
- 6 Green (RGB signal)
- 7 Red (RGB signal)
- 8 Blue (RGB signal)

Cable Connector hookup

Pin #1, 8 pin Din connector to pin #14, IC-1 (+ 5 Volts DC)

Pin #2, 8 pin 'Din connector to pin #7, IC-1 (Common Ground)

Pin #3, 8 pin Din connector NOT USED!

Pin #4, 8 pin Din connector to pin #'s 1 & 2, IC-1 (Horizontal sync input)

Pin #5, 8 pin Din connector to pin #9, 9 pin 'D' connector (Vertical Sync)
 Pin #6, 8 pin Din connector to pin #4, 9 pin 'D' connector (Green RGB signal)
 Pin #7, 8 pin Din connector to pin #3, 9 pin 'D' connector (Red RGB signal)
 Pin #8, 8 pin Din connector to pin #5, 9 pin 'D' connector (Blue RGB signal)

Pin #1 and #2, 9 pin 'D' connector to pin #7, IC-1 (Common Ground)
 Pin #3, 9 pin 'D' connector to pin #7, 8 pin Din connector (Red RGB signal)
 Pin #4, 9 pin 'D' connector to pin #6, 8 pin Din connector (Green RGB signal)
 Pin #5, 9 pin 'D' connector to pin #8, 8 pin Din connector (Blue RGB signal)
 Pin #6 & #7, 9 pin 'D' connector NO CONNECTION
 Pin #8, 9 pin 'D' connector to pin #3, IC-1 (Positive Horizontal sync output)
 Pin #9, 9 pin 'D' connector to pin #5, 8 pin Din connector if required (Vertical sync)
 Pin #'s 1 & 2, IC-1 to pin #4, 9 pin 'D' connector (Negative Horizontal sync)
 Pin #3, IC-1, to pin #8, pin 'D' connector (Positive Horizontal sync out)
 Pin #7, IC-1 (two wires), to pin #'s 1 & 2, 9 pin 'D' connector and to pin #2, 8 pin Din connector
 Pin #14, IC-1, to pin #1, 8 pin Din connector (Pin #1 is labeled PAL in the QL manual, however, the US QL's have a 5 volt DC connection at this pin).

List of parts: Radio Shack part numbers indicated

274-026	8 pin male DIN plug	\$1.79
276-1537	9 pin male 'D' plug	\$0.99
276-1539	9 pos 'D' Hood	\$0.79
276-1801	7400 Quad 2-input NAND gate	\$0.89
276-1802	7404 Hex inverter	\$0.99 *
278-775	9 conductor, double shielded cable	\$0.59 per foot

* Use the 7404 Hex inverter as an alternate IC.

Additional Information:

An RGB monitor will display 8 primary colors; black, red, yellow, cyan, green, blue, magenta and white. If you purchase a CGA monitor, yellow will appear brown and white will be tinted blue or dirty looking. This is set-up in the G2's (grids of the picture tube) to produce these differences in color because; CGA monitors have one additional line called Intensity. CGA will provide 16 colors if the intensity line is used - IBM only! Yellow will be yellow when intensified and white will be white. You may also find that when you power-up the QL, the tweed memory check display and the F1 - F2 display will roll until you press either function key; then it will stabilize. Try not using the vertical sync line, it may eliminate this problem.

NOTE: If you require any assistance, contact me through LIST.

Bob Gilder.....

LISTings
 NEWSLETTER
 March 1991

CASSETTE TAPE LOAD / SAVE MONITOR

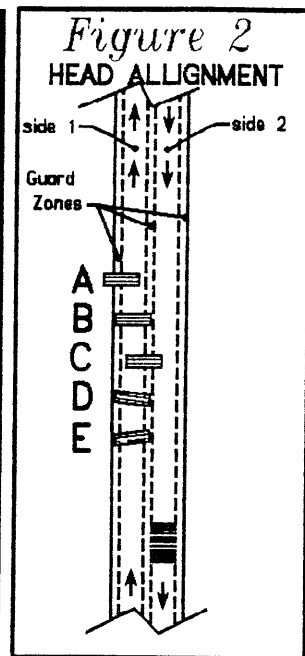
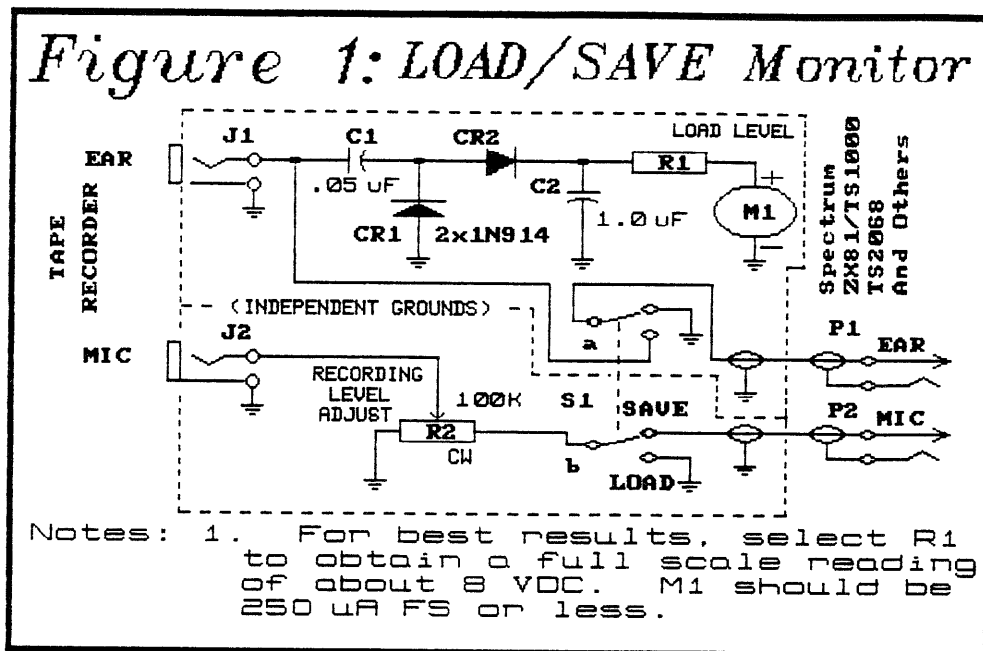

by William Pederson
 One problem is the feedback generated by most cassettes recorders. So you have to pull one of the EAR plugs when SAVEing.

A second is feeding the cassette recorder too strong a signal. For the ZX81/TS1000 this is seldom a problem, its signal is weak, The TS2068 puts out a relatively ear-splitting signal.

A third is getting the right amount of signal to the computer for successful LOAD. The ZX81/TS1000 is very finicky. It is so obstinate that a commercial tape will seldom LOAD with setting the user found to be optimum.

A TS2068 needs about 6 V. P-P for best results, though this range is quite wide. The level for the ZX81/TS1000 is near 1 V. P-P.

The first problem is solved by using a switch instead of pulling an EAR connection. Other things can be done, like grounding out stray signals.

The second problem is solved by potentiometer R2 which allows you to control the signal strength heard by the recorder.

The third problem is solved by a Peak-to-Peak voltmeter for the EAR signal so you can see what you are getting before attempting to LOAD. Sometime you can even adjust the level on the fly to salvage a cassette that fades out.

Unless you really have horrible tapes, this will solve your problem. Of course you might have an equally horrible recorder. In that case, this monitor comes in handy for finding out what kind of output you are getting.

There has been a lot said about head alignment being the major cause. Oscilloscope picture Fig. 2 shows this unlikely. The effect of head misalignment is not severe it rounds off the corners and reduces signal strength. In severe cases like (C, D, E) more than one magnetized strip is seen by the head. Luckily, this is almost never the case.

Signal conditioners like WINKY Board are best used to salvage tapes made on bad recorders.

Technical Information

The CM-11 is designed for connection to a non-interlaced 225-line signal, 15.701KHz scanning frequency. When the CM-11 is connected to a computer with other than the specified input signal, distortion in the display image, shape, and position may be due to the inadequate input signal of some computers. The following chart illustrates such conditions.

Symptom	Cause
Shrunken screen	Data display period is too short.
Expanded screen	Data display period is too long.
Image to left or right	Data display period is out of alignment.
Moving screen	Synchronization period is different.
Dark screen	Front and back porch of video signal is missing.

Input Signal

Video Signal	Horizontal Sync.	Vertical Sync.
RGB and Intensity Separate	TTL-Positive	TTL-Positive

Timing Chart

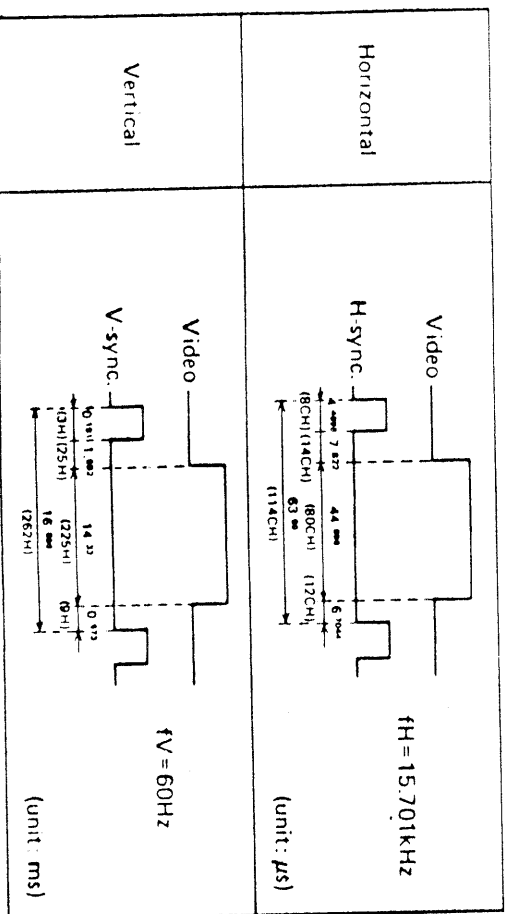

WILLIAM B. HORNER III
 4311 BUCKINGHAM
 DETROIT MI 48224
 FETE: (313) 882-2737

Technical Information

Input Connector

The connector is a 9-pin, Sub-D type. The relation between pins and signals is as follows:

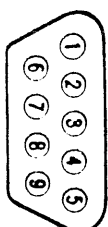

Pin No.	Signal
1	Ground
2	Ground
3	R (Red Video)
4	G (Green Video)
5	B (Blue Video)
6	Intensity
7	No connect
8	Horizontal Sync.
9	Vertical Sync.

Specifications

- Power Supply: 120V AC, 60Hz
- AC Input Current: 0.9A
- BTU/Hr.: 205
- CRT: 13" diagonal, 90° deflection, high contrast, non-glare picture tube, 0.42 mm stripe pitch, P22 Phosphor Red, green, and blue (RGB) video and intensity, vertical and horizontal synchronization
- Input Signal: Video TTL-positive, intensity TTL-positive, vertical and horizontal synchronization, TTL-positive
- Input Level: 9-pin, Sub-D connector with cable
- Input Connector: 9-pin, Sub-D connector with cable
- Scanning Frequency: 15.701KHz±500Hz
- Horizontal: 60Hz±1.0Hz
- Vertical: 9.27/32" x 7.15/32" (250mm x 190mm)
- Display Size: 640 dots x 225 lines (within display size)
- Resolution: Approximately 2000 (25 lines of 80 characters)
- Character Number: 13-11/16"(W) x 12-17/32"(H) x 15-1/8"(D)
- Cabinet Dimensions: (348mm(W) x 318mm(H) x 384.5mm(D))
- Weight: Approximately 23 lbs. 2 ozs. (10.5kg)
- Power Cord: Approximately 6 ft. (1.83m)

FROM THE CHAIRMAN'S DISK

Sometimes I am like a computer - I sit here with a blank mind and I have a column to write. But sitting at the left upper corner of my T/S 2068 is a joystick that I bought for \$2.00 at the Ft. Wayne HamFest and ComputerFest on November 13th. The joystick is a WICO COMMAND CONTROL which was offered by a table with a lot of Commodore stuff. It works very well and the stick looks like it saw little wear.

They were dealing very well, in fact if you weren't really wanting to buy you should not make an offer when asked to since they just might accept a ridiculous offer. For instance I say two quite dirty full height 5.25 disk drives with a tag that read \$5.00 each. Out of curiosity I lifted them up to see what make and model and they were Tandon TM 100-2A and the seller said they were a bargain. "Very dirty and overpriced," I said. "Make an offer" and I offered \$1.00 for both of them. So my "loot bag" got heavier. Not a total loss since they both worked as is but not without some bell ringing on my Oliger disk system. I wrapped them in newspapers and stored them with other disk drives I have. I wanted to keep the other disk drives clean. One other good buy and at my price was a book. "The Brady Guide To Microcomputer Troubleshooting & Maintenance" by Henry F. Beechhold for \$2.00. It gave me lots of clues on how to clean a dirty drive.

My very first buy was a full height single drive case with a Radio Shack disk drive in it. Very compact case and very clean. The case even had an extender for the ribbon cable which meant that I did not have to open the

case to plug in the ribbon cable to test the drive. And as I knew it would be, it was a single sided 40 track drive, a TEXAS Peripherals drive. Worked very nicely with no changes to the drive select socket. But it is single sided. I bought the case with the idea of having a pair of half height 40 track drives put in it. A school was selling all their Radio Shack equipment since they have upgraded to a MSDOS clone.

I did buy what was supposed to be 40 track 360K half height drives but turned out to be 720K 80 track drives when I tested them at home. They were marked 360K drives and in another stack was a sign 720K and I wonder if the signs got mixed. He wanted three times as much for the 720K drives. I will have to watch for another chance to buy a 360K drive or two that is half height. What I got is a pair of TEAC 55GFR-553-U drives. I am after a set of drives that is easier to transport to meetings.

The computer column in Popular Electronics (January 1994 issue) was moaning about the fact that the computer industry does not have a full complement of engineers. What they need is a DOCUMENT ENGINEER to write the manuals so that they make sense and are well written. He suggested that a DOCUMENT ENGINEER should have a Masters in English and at least a Masters in computer programming. So that would require a DOCUMENT ENGINEER to have at least a Doctor's degree. And here I am trying to write a document to explain how to use a rather simple program and I am not a programmer!

**GO -
PER
IT!!**



Here I am trying to swim and I can not even float yet!

If anyone is using SPDOS (RAMEX Millenia K) there is one oddity that will make you think that the computer and SPDOS has locked up. In both the Larken and the Oliger disk systems the interfaces try to LOAD or SAVE 5 or 6 times before reporting an error. But SPDOS makes 50 tries. So if it goes off with a blank screen and the disk drive is running that is what is happening. Amazing what one can learn if you read and reread the manual.

Yesterday, November 24th, I took another look at the full height drive and case I bought at the HamFest and saw that since the cable connector was extended to outside the case that I could easily use the case without the process of making slots in it for the ribbon cable to add a third drive to the 3.5 and 5.25 720K drives in another case. I remembered my prior try with a 3.5 drive and that nothing worked when it was on line so I thought that it was worth a try since this was a different type of 3.5 drive. I had to swap the SSDD drive with a DSDD drive and then add a connector to the ribbon cable on the 720K case. I made the DSDD drive (a TANDON TM 100-2A drive) drive #2 although it is the first on the line of the ones on the cable. Also since the other drives had no place for a terminator resistor I tried it with out one. I had success with the setup. So now I have three drives in two cases to represent a 3.5 720K and 5.25 both 360K and 720K drives. I was even dreaming of a 3 inch drive but I did not see any place to get disks so that is out. But does anyone even use the 3 inch drives?

I have used the Oliger disk interface so much and even when using the Larken interface it does the same disk drive light on the selected drive that it does on the Oliger interface alone. Now what I am writing about is the LED on the front of every drive. On the Larken interface it only comes on when the drive is in use but on the Oliger it is on all the time on whatever drive is the selected drive. Why the comment? Well, I was recently set-

ting up a set of three drives for my traveling computer and it has a pure Larken interface. I was testing them and panicked until I realized that on the Larken the selected drive's light does not light up till it is in use. I thought that the system was down. I had gotten so used to looking at the drives to see which was selected that I forgot about the way that the Larken handles the drive light. On the Oliger even in the Larken mode the drive light is on all the time.

This week (today is 12 03 1993) I received more information on how Richard Jelen is converting his T/S 2068 into a portable using nicad batteries to power it and a 12 volt TV. I will include the material in the next issue of ZXir QLive Alive! since I will have to type in the hand written material and get the sketches and drawings included. He did cut the current draw using some CMOS chips. One other project Mr. Jelen is involved in is building up a disk interface from bare boards he ordered from John Oliger. See the cassette LOAD AID circuit schematic that is in this issue for some of his earlier work.

MSDOS to LarKen and MSCRIPT.

Letter from Les Cottrell, Cocoa, FL.

I have done this several times using two different schemes. The last time I took a file done on a MAC in MSWord, moved it across a network SAVED as an ASCII file to an IBM and then to Larken. To make it easy to find I use a disk with only the files I want to convert.

1. Using the Larken Disk Editor I searched using the "Edit a block" function until I find the beginning of the text I want. I write down the address and look for the end of the text on that block and write that down. Also look for any ASCII codes that won't be in MSCRIPT such as 9 for tab. (MSCRIPT tab stops are "padded" with spaces - 32's.) Then I break out of the Editor and do a code

save such as "text1.CT" CODE (start), (length). You may find more than one place with MSDOS text on a Larken block so I save the next as "text2.CT CODE (start), (length). This process is repeated until all the text is located and SAVED over to Larken files.

2. Then I load MSCRIPT and load "text1.CT". If you then look at a file with tabs in it will have short lines where tabs were. I then break out of MSCRIPT and add a few lines of basic to correct this such as:

```
1000 FOR 1=46927 to
(46927+length of file):IF PEEK 1=9 THEN
POKE 1,32
1010 NEXT 1
```

Then GOTO 1000 will find the tabs and replace them with a single space. MSCRIPT doesn't have much room left for added basic so keep it short. The last line of basic in my version of MSCRIPT is 950 so 1000 was a safe starting point. 46927 is where the CT files start and of course 32 is a space. You could also delete the unknown codes using "delete left" or "delete" keys if you only had a few problems. After I finish this I always delete lines 1000 and 1010 just in case.

3. Next I run MSCRIPT and add spaces where needed to get the tabs lined up. Some other cleanup such as added carriage returns might also be required. File is SAVED with a new name from MSCRIPT.

4. Steps 2 and 3 are repeated until all the files are cleaned up.

5. Now I would load "name1" and assuming that it was only part of what I had in MSDOS I would merge "name2" and so on until I had the file recreated in MSCRIPT. The is SAVED again as "final1".

The last file that I converted was the Larken DOS cartridge disassembly that was done in 2 columns as I had quite a bit of cleanup, but I ended up with the same thing in MSCRIPT that I had started out with in MSWord on the MAC.

The other method is to use a utility called MSDOS.Bx written by George Chambers of the Toronto Users Club and published on page 8 of May '90 Sinc-Link. (George Chambers; 14 Richome Court; Scarborough, Ontario; Canada M1K 2Y1) He has built the "unknown" code remover into his program. I used this program to convert the index of all Sinc-Link articles from MSDOS disk to MSCRIPT and it worked quite well.

Editor's comments: I have used George Chambers' MSDOSOS.Bx several times but I thought that Les's information would be helpful to someone with other than a Larken interface. If someone gets this running on other than a Larken disk interface please let me know or let Frank Davis of UPDATE MAGAZINE know because it might be handy for someone else to use. (UPDATE MAGAZINE; P. O. BOX 1095; Peru IN 46970). Further information is available in the form of documents for MSDOS.Bx which I can supply. 0/0

D.U.S.

DISK UTILITY SOFTWARE

By Donald S. Lambert

Comments about one of the programs that I have used.

If you have a virgin copy of D.U. S. do not ever remove the write protect sticker. Any dedicating to the programs should be done on a copy disk. Get the copy done first, copy by any means the program COPYII.B1 and then dedicate that copy. When the program COPYII.B1 is LOADED it will halt with a line or two of programming and a warning of some kind. EDIT the line and between the quotes of the A\$ enter the letter given that applies to your disk interface. Run the cursor over to get in between the quotes in LET A\$="". Use only capitals and if you have a pure Larken interface use an "L", if a Larken on an AERCO interface use an "A", if a Larken on a RAMEX interface use an "R" and if a Larken on an Oliger interface use an "O". It must be an upper

case letter. And then RUN 9999 and that will automatically (you must not write protect the disk till this is done) SAVE that to disk. This is what the program will display on the screen till it is dedicated:

```
9910>LET a$="": IF a$="" THEN
PRINT AT VAL "5",NOT PI; "THIS PRO-
GRAM MUST BE CUSTOMIZED!""":
BEEP VAL ".25",NOT PI BEEP VAL
".25",NOT PI: LIST VAL "9910": STOP
9920 PRINT #VAL "4": LOAD
"COPYIL.C"+A$CODE : RUN VAL "5"
9999 RANDOMIZE USR VAL "100":
SAVE "COPYIL.B1" LINE VAL "9990"
```

Now run the program and it will ask you for the original drive number, then the number of copies to be made and finally the drive the copy will be made in. The drives must be the same number of tracks both 40 track or both 80 track (size of the disk is immaterial) and both have the same number of sides or at least the target disk needs to have the same or more sides than the original. Now with a working COPYIL.B1 program you are ready to copy the master disk. COPYIL.B1 will copy the original disk exactly as it is on the disk, same number of sides, same disk title and same number of tracks plus the same head step rate. And it does it at the rate of 5 tracks at a time and then as it SAVES to the target disk it FORMATS the disk. And it will report if the disk has something wrong with it. If the copy work ends with a notice BAD DISK it is bad and try again. In either case (good disk - it doesn't say good but if a bad disk it does say BAD) you will be asked ANOTHER? if so press "Y" and it will have you set up for the next copying routine. As it copies it will tell you how many tracks and sides the disk has plus head speed.

When I send a disk to Bob Swoger I use COPYIL.B1 to make up the disk for me from a master disk I made back when. The reason for this is that Bob uses a single sided drive and only 40 tracks but he requires a head step rate of 30. COPYIL.B1 does all that so that I don't have to worry about getting all the current information on the disk and since

LogiCall is on the disk that also is there ready to use.

When you use the full disk you will find that it will load by pressing ENTER and powering up the computer. The screen will clear and then the first display will be on the screen. If you wait a while then it will progress to the menu display, but if you hit enter when the first display is shown it will immediately go to the menu. The menu will not display all the programs, use the up and down arrow keys to get the other titles. Then enter the letter for the one that you want and that program will be LOADED into the computer. The letters that you ENTER will not change as the titles scroll up or down but the computer knows what you want.

I had a disk that the Oliger disk interface quit at about the tenth or twelfth track. Now I could FORMAT that with FORMAT.B1 (Has to be customized) on the Larken disk interface and that will report how many bad bytes. But still it can end up with a problem. So after Formatting with FORMAT.B1 I used MAPOUT.B1. MAPOUT.B1 will go through a disk and map out the bad blocks so that you never need worry about a failed program from a block with a bad byte. I have added the screen displays for the various above programs:

This shows the result of Formatting with bad bytes.

```
FORMAT DISK
WRITTEN BY KRIS BOISVERT
1989 BYTE POWER
```

```
FORMATTING DISK IN DRIVE 0
2 SIDES, 43 TRACKS, 6 ms
```

```
FORMATING COMPLETED...
256000 BYTES IN BAD BLOCKS
409600 BYTES AVAILABLE ON DISK
```

And this is the result of using MAPOUT.B1 with LogiCall installed on the above disk:

```
Disk Name : Lambert 11 27 1993
L.B1      001      AUTOSTART 001
```

LarKen LKDOS ©1986
Track/Side 043/002
Total Files 002
Free Blocks 076

And since the drive call-out on MAPOUT.B1 lists the drives as 0-4 then apparently it will work with RAMDISK.

Conclusion: If you have the Larken disk interface then this is a must have disk. The other must have is George Chambers' utility disk of TTSUC Library Disk #1. (also ZQA! PD Lib. Disk #9) What one disk won't do the other will very likely do. In addition there is provision on the D.U. S. disk to convert the menu load program to your own use. And an important factor is that the D.U. S. disk is almost so user friendly so that the manual is not required for every program. 0/0

Note: D.U.S. is a Public Domain disk. Page 2, § 4 of the manual reads:-
D.U.S. is Public Domain, this means you may freely distribute it to any LarKen LK-DOS user so long as no charge is made for the package other than the cost of the media and/or time. Also, you must distribute exact copies of the disk(s), no program should be altered in anyway without first consulting me. etc.

Kiristian Boisvert

How about it Don, can we add it to our P D Library? Abed

TURBO SWITCH For The ZX-81

by Tony Willing, Vashon, WA

The whole idea of experimenting with a "TURBO Switch" came from reading the book "EXPLORER'S GUIDE TO THE T/S 1000" by Mike Lord. On page 58(1) of this book under the heading "Keyboard Scanning" he tells how the system variable MARGIN may be changed from 55 to 31 by taking pin 22 of the ULA chip HIGH or LOW. This is supposed to be of use to the computer manufacturer to enable the T/S 1000 to be used in either the USA which uses 31 blank lines at the top and bottom of the screen, or in the UK which uses 55 blank line. The

book also states on page 52(2) under the heading "NMI Handler" that "When in the SLOW mode the ZX81 uses the time occupied by these blank lines to carry on with your program".

So I thought if I increased the number of lines on my T/S 1000. I might increase the speed of program execution. And it works well. I use direct video and have not tried it using the RF modulator, but if you use direct video I think you will have success from the modification.

To test the speed of program execution I use the following BASIC program:

```
10 FOR N = 1 TO 500  
20 NEXT N  
30 PRINT "FINISHED"
```

With pin 22 HIGH the computer takes 20 seconds. With the pin low, the program takes 28 seconds. (About a 28% increase in speed. Don). This is a considerable increase in speed. One might ask "Why have a TURBO Switch?" Well, when I use my WORD* program (word processor) at the "TURBO" speed the cursor blinks at about twice the normal rate and does not seem to miss keys as it did in the past, and when playing games I use the slower speed so that I can get a higher score!

When using the higher speed I find the monitor screen is filled with lines from top to bottom, when using the slow speed I find a blank screen at the top and bottom 1/2 inch of the screen. I can switch from "TURBO" to normal at any time without any crashes.

Lastly, how is the modification carried out? You have to take the T/S 1000 circuit board out of it's case and locate resistor R30 which is located between the ULA chip and the regulator heat sink. It should have the colors Brown Black Brown.

Using a soldering iron, lift the left hand end of the resistor clear from the circuit board hole. Also locate resistor R38 which is four resistors down from R30, and solder one end of some two core cable to the left hand end of R38, which should be a 5V rail. To the raised left hand end of R30, solder

one end of a 1K 1/4W resistor. Bend the resistor upwards and solder the other end to the right hand end of R34, which is a 0V rail. To the junction of R30 and the added 1K resistor solder the other core of the two core cable. To the other end of the cable solder a switch of the single throw single pole type.

change the voltage from nearly 0Volts to nearly 5Volts, and if you have your monitor connected you should see the screen flicker.

The switch should be mounted somewhere convenient, accessible from outside the T/S 1000. I have my T/S 1000 mounted inside a steel chassis and so I mounted the

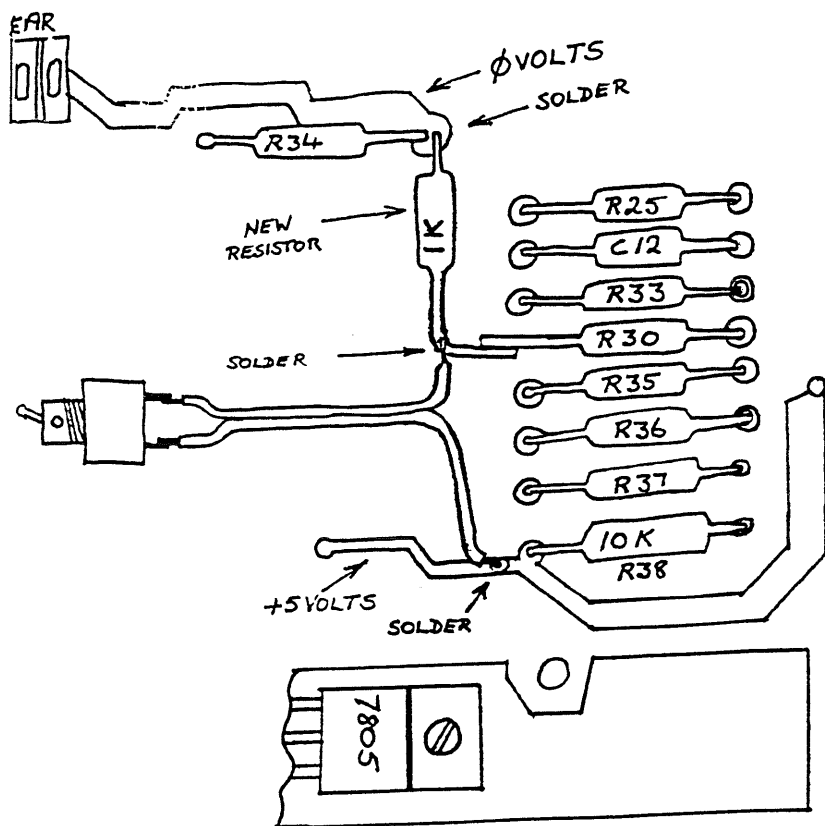

PARTS REQUIRED.

- 1 x SP/ST SWITCH
- 1 x 1K 1/4W RESISTOR
- 1 x RIBBON CABLE (6"LC)

TURBO/NORMAL SWITCH MODIFICATION FOR T/S1000.

ORIGINAL CIRCUIT

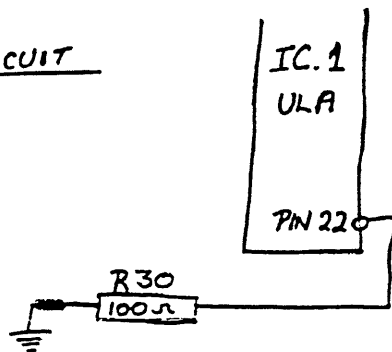

That completes the circuit board modification. Try connecting a multimeter at the solder connection between R30 and the 1K resistor, and ground. When the T/S 1000 is powered up, the "TURBO" switch should

MODIFIED CIRCUIT.

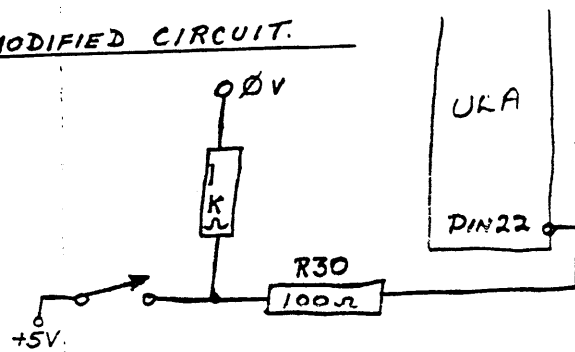

"TURBO" switch on the front panel with the words "TURBO" and "NORMAL" along side the switch. Try ENTERing and running the program that I LISTed earlier and see the difference the switch makes. ENJOY!

(1)(Page 58) KEYBOARD SCANNING

This is a fairly straightforward subroutine which is normally called from the Main Display routine, but which can equally well be used by your machine language programs.

It returns a code in the ILL register pair corresponding to the key pressed, or FFFF if no key was pressed. It also loads the System Variable Margin (4028) with the correct number of blank lines needed at the top and bottom of the picture; 55 for U. K. machines, 31 for the U. S. A. models, by detecting whether pin 22 of IC1 is strapped to 0V or not.

(2)(Page 52) NMI HANDLER

As each horizontal TV scan line is completed in 64 micro-seconds, it takes 24 X 8 X 64 micro-seconds - which is just over 12 milli-seconds - to output the complete 24 rows of characters displayed in each TV frame. But, to synchronize the TV set properly, each frame must last for 20 milli-seconds (16.7 milli-seconds for the U. S. A. model), so additional - blank lines are needed to fill in the top and bottom margins of the picture, before during and after the frame synchronization pulse.

When in the SLOW mode, the ZX81 uses the time occupied by these blank lines to carry on with your program. But, to keep track of the time, it is interrupted by the SCL chip every 64 micro-seconds. The non-Maskable Interrupt is used for this function, and calls the routine starting at 0066 hex. 0/0.

USING A 16K MEMOTECH MEMOPAK THAT HAS SWITCHES

by Donald S. Lambert

This was in a letter that I wrote to Gilliam Parrish in regards to using a 16K MEMOTECH MEMOPAK.

At the Dayton ComputerFest I did find a 16K Memotech ram module of the latter manufacture with the DIP switches which are located where the oval opening in the back is. I really did not know that they made two versions but am not surprised. And

I would expect that it could be possible to upgrade a switchless version to one with switches. How much circuitry would have to be changed is not known. But the switchless version will not work with more than 16K of memory.

But this is what the manual stated:

HOW DO I SET UP THE MEMOTECH 16K?

Make sure your power supply is not connected to the ZX81 when you attach the pack. We recommend that the ZX81 + (this was wrote in the U. K. where they never had the T/S 1000) MEMOPAK configuration should go in this order, according to what add-ons you have:

ZX81 + (Commercial Printer I/F) + (HRG) + Master Memopak 16K or 32K + (Sinclair Printer - Silver paper one) + (Slave Memopak or Sinclair 16K). (You will have to experiment to find out where to connect the T/S 2040 printer.)

WHAT ABOUT THE SWITCH SETTINGS?

There are two possible modes for using the Memopak 16K: MASTER and SLAVE. The mode you require depends on which of the possible memory configurations you are using. The configurations and modes are as follows:

- a) MEMOPAK 16K alone (MASTER).
- b) MEMOPAK 16K (MASTER) + MEMOPAK 16K (SLAVE).
- c) MEMOPAK 16K (MASTER) + SINCLAIR 16K (SLAVE).
- d) MEMOPAK 32K (MASTER) + MEMOPAK 16K (SLAVE).

Now, if your MEMOPAK 16K is being used as a MASTER (alone or with a SLAVE pack attached somewhere behind) then switches 2 and 3 should be ON and switches 1 and 4 should be OFF. On the other hand, if your MEMOPAK is sitting behind a MEMOPAK 32K or another 16K then it should be switched into SLAVE mode (1 and 4 ON and 2 and 3 OFF).

REMEMBER "ON" IS UP.

WHAT SHOULD I DO TO USE THE NEW, LARGER MEMORY?

If you have a total of 32K RAM then to make the most of it you'll need to key in:

POKE 16389,192

NEW

To raise the RAMTOP. For the 48K RAM, you should key in:

POKE 16388,255

POKE 16389,255

NEW

To check RAMTOP, type in:

PRINT PEEK 16389

NEW

and you will get back the current RAMTOP. This should be 192 for 32K of memory. If I remember right 2K should get 72,

16K should get 128, 32K should get 192. Remember that the default is to 16K (128).

With 32K of memory you will have to watch that the display file does not straddle the 32K mark (ROM is 8K, 8K is set aside for use of some accessories) which is where the RAM starts at 16384 (16K times 1024). And that means that 16K of RAM has a RAM top of 32768. So you need to fool the computer and jump the program above the 32768 mark and later that can be edited out of the program.

If you wanted to convert your old style 16K MEMOPAK to the new style Dan Elliott probably could do it. But on the other hand it might be cheaper to go to a new MEMOPAK or a static RAM memory. 0/0

U N C L A S S I F I E D A D S

SPECTRUM for your 2068

If you are a LarKen LK-DOS owner and would like to run SPECTRUM programs on your system, we will supply a V2 EPROM, socket and 74HCT32 for \$12 which includes shipping and handling. The installation instructions are in your LarKen manual. We shall not be responsible for your install job. AERCO owners need only the EPROM for \$10 forwarded to LarKen.

Bob Swoger Address on page 2

747 Flight Simulator

So you like to fly, the 747 Flight Simulator for SPECTRUM by Derek Ashton of DACC sold over 40K copies in Europe. Requires a SPECTRUM equipped 2068. At this time supplied on LarKen SSDD disk only for \$10 which goes to Derek now working at Motorola with Bob.

Bob Swoger Address on page 2

PAL Chips

Programmable Array Logic chips are available for some Timex or QL's from NAP_Ware.

Nazir Pashtoon

940 Beau Dr. Apt. 204

Des Plaines IL 60016-5876

Phone(eve.) 708 439-1679

Update! Magazine

Our Only Magazine

513 E MAIN ST

PERU IN 46970

317 473-8031

CONQUEST

A Strategic Generic War Game for the 2068

TIME: A few centuries from now.

PLACE: An unknown inhabited planet.

YOU: Commander of Expeditionary Force.

MISSION: Capture said planet.

INTELLIGENCE: Enemy seen scouting same planet.

STRATEGY: Find and capture Planet's cities.

Direct production to aid your war effort.

Defeat enemy when found.

SITUATION: You have just captured your first city.

Can generate new random map every time or play map of your choice.

For 2 or 3 combatants. Play against the computer or your friends.

Production times and fighting ability adjustable for each player - keeps game a challenge at all times.

☐ Completely in fast machine code. Games can be SAVED and CONTINUED.

Available on tape, or disk, AERCO, Oliger. Game and map SAVES in BASIC to allow adaptation to your system. Price \$19.95 + \$2.50 S&H.

<u>Order from:-</u>	<u>or</u>
Lloyd Dreger	SMUG
2461 S. 79th St.	BOX 101
West Allis WI 53219	Butler WI 53007

The John Oliger Co.

11601 Widbey Dr.
Cumberland IN 46229

The John Oliger Floppy Disk System :- DISK BOARD "A"

Bare PC Board only : \$17.95 pp.

Kit of PC Board & parts : \$55.95 pp.

Assembled and tested : \$66.95 pp.

Two drive cable for above, 3 foot long: \$16.95 pp.

Four drive cable for above, 4 foot long : \$26.95 pp.

DISK BOARD "B"

Bare Board with JLO Safe Disk EPROM : \$26.95 pp.

Kit of PC Board with parts : \$45.85 pp.

Assembled and tested : \$63.95 pp.

PACKAGE OF BOTH DISK BOARDS "A" & "B"

Bare PC Board with JLO Safe EPROM : \$43.95 pp.

Kit of both Boards with parts : \$99.95 pp.

Both Boards assembled and tested : \$127.95 pp.

Both Boards assembled and tested w/2-drive data cable : \$139.95 pp.

THE DISKWORKS: Both Boards assembled and tested w/2-drive data cable and assembled 2068 EXPANSION Board : \$189.95 pp.

2068 EXPANSION BOARD : plugs in the expansion port on back of 2068. Pass-thru for other peripherals, giving you 4 expansion slots. All devices use this Board, except for the 2068 dock cartridge Board.

Bare PC Board : \$14.95

Board with parts : \$43.95

Assembled & tested : \$54.95

Indiana residents, please add 5% sales tax

LISTing Newsletter.

Annual dues to receive LISTing is \$16.00. Fred Stern is the editor and is doing great in keeping it going.

LIST

5 PERI LANE

VALLEY STREAM NY 11581

WANTED: MINI-MOD AND Z-COM documents. They are modem programs for the T/S 1000.

FREDERIC STERN

P. O. BOX 264

HOLBROOK NY 11741

Tele: (516) 737-0963

WANTED: Articles or material for the QL and the Z88 for publication in ZXir QLive Alive!. Also articles on any other T/S computer. Can't publish what we do not have. Will accept even hand-written notes.

DONALD S. LAMBERT

1301 KIBLINGER PLACE

AUBURN IN 46706-3010

FREEBIE! Take a look where your disk drive interface cable comes out of the disk case. If you have a sharp piece of metal (all my metal cases had) and want to protect your interface cable from wear here is a deal. I have some plastic protectors that are 3.5 inches long (49 of them) and some that are 2.75 inches long. They are easy to cut to length if necessary (mine all were) and the protector are such that they will slide onto a piece of metal or plastic that is up to about .050 inches thick. To get one or so send a stamped self addressed letter and I will send you up to 3 per request. These were given to me by Paul Holmgren to be passed on. DONALD S. LAMBERT; 1301 KIBLINGER PLACE; AUBURN IN 46706.

FRANK DAVIS

MECHANICAL AFFINITY

513 E MAIN ST

PERU IN 46970

317 473-8031

Z88 QL GOLD CARDS QXL Card

Falkenberg Hard Drive Interface

TEXT78PLUS4

Software Hardware and Disks
For T/S Computers

PAUL HOLMGREN

MECHANICAL AFFINITY

5231 WILTON WOOD CT

INDIANAPOLIS IN 46254

317 291-6002